

September 2003

# NEMA Contactors & Starters

## Contents

<i>Description</i>	<i>Page</i>
<b>IT. Electro-Mechanical</b> .....	<b>2</b>
Product Family Overview .....	2
Catalog Number Selection .....	3
Contactors — Full Voltage, Non-reversing and Reversing .....	4
Starters — Full Voltage, Non-reversing and Reversing .....	7
Technical Data and Specifications .....	10
Accessories .....	13
Dimensions .....	18

**Note:** Supplement to Publication No. CA8102001E — Tab 33.

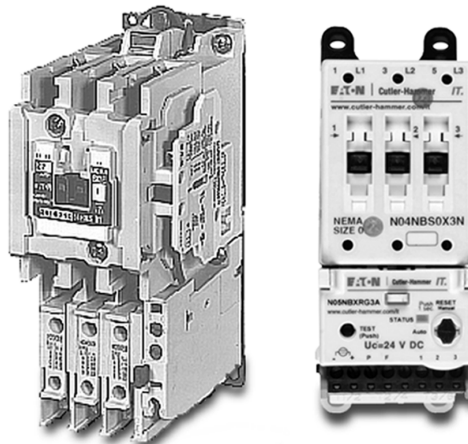

*NEMA Contactors and Starters*

### Product Family Overview



**NEMA, Size 0**  
**Full Voltage Non-reversing Starter**

## Product Description

Eaton's Cutler-Hammer Intelligent Technologies (IT) Electro-Mechanical line of Contactors and Starters is the result of a substantial engineering, manufacturing and marketing effort involving extensive customer input, combined with new advances in solid-state technology. IT Electro-Mechanical products have greatly increased functionality, significantly reduced size and utilize the benefits of 24V DC control. The exclusive Pulse Width Modulation (PWM) control and digital microprocessor generate a minimized DC value which reduces energy to the contact block and provides the most compact system available.

## Standards and Certifications

- Standard: Designed to meet or exceed UL, NEMA and CSA
- UL Listed: UL File #E1491, Guide #NLDX — Open, UL 508
- CSA Certified: CSA File #156828, Class #3211 04 Open, C22.2 No. 14-95
- CE
- NEMA ICS1, ICS2, ICS5



## ISO 9002 Certification

When you turn to Eaton's Cutler-Hammer Products, you turn to quality. The International Standards Organization (ISO) has established a series of standards acknowledged by 91 industrialized nations to bring harmony to the international quest for quality. The ISO Certification process covers 20 quality system elements in design, production and installation that must conform to achieve registration. This commitment to quality will result in increased product reliability and total customer satisfaction.

## Publications

- Pub. MN03305002E **IT.** NEMA Overload Relay Setup and Troubleshooting Manual
- Pub. MN03305001E **IT.** NEMA Contactor and Starter User Manual
- Pub. MN03403002E **IT.** IEC Contactor and Starter User Manual
- Pub. 50102 **IT.** NEMA Overload Relay Quick Setup Guide
- Pub. 49416 **IT.** NEMA Contact Blocks (Size 00 – 4)
- Pub. 50140 **IT.** NEMA Non-reversing Contactor Size 00 and 0 Installation Guide
- Pub. 50150 **IT.** NEMA Non-reversing Contactor Size 1 Installation Guide
- Pub. 50160 **IT.** NEMA Non-reversing Contactor Size 2 Installation Guide
- Pub. 50170 **IT.** NEMA Non-reversing Contactor Size 3 and 4 Installation Guide
- Pub. 50180 **IT.** NEMA Non-reversing Contactor Size 5 Installation Guide
- Pub. 50141 **IT.** NEMA Reversing Contactor Size 00 and 0 Installation Guide
- Pub. 50151 **IT.** NEMA Reversing Contactor Size 1 Installation Guide
- Pub. 50161 **IT.** NEMA Reversing Contactor Size 2 Installation Guide
- Pub. 50171 **IT.** NEMA Reversing Contactor Size 3 and 4 Installation Guide
- Pub. 50181 **IT.** NEMA Reversing Contactor Size 5 Installation Guide
- Pub. 50142 **IT.** NEMA Non-reversing Starter Size 00 and 0 Installation Guide
- Pub. 50152 **IT.** NEMA Non-reversing Starter Size 1 Installation Guide
- Pub. 50162 **IT.** NEMA Non-reversing Starter Size 2 Installation Guide
- Pub. 50172 **IT.** NEMA Non-reversing Starter Size 3 and 4 Installation Guide
- Pub. 50182 **IT.** NEMA Non-reversing Starter Size 5 Installation Guide
- Pub. 50143 **IT.** NEMA Reversing Starter Size 00 and 0 Installation Guide
- Pub. 50153 **IT.** NEMA Reversing Starter Size 1 Installation Guide
- Pub. 50163 **IT.** NEMA Reversing Starter Size 2 Installation Guide
- Pub. 50173 **IT.** NEMA Reversing Starter Size 3 and 4 Installation Guide
- Pub. 50183 **IT.** NEMA Reversing Starter Size 5 Installation Guide

For copies of these and other publications, contact the Literature Fulfillment Center at 800-957-7050, Fax: 877-840-2371 or find on-line at: [www.cutler-hammer.eaton.com/it](http://www.cutler-hammer.eaton.com/it).

For International, call: (630) 377-9798 (English only), Fax: (630) 377-1753.

E-mail: [wcsorders@wallace.com](mailto:wcsorders@wallace.com)

Mail: Cutler-Hammer Fulfillment Center  
1750 Wallace Avenue  
St. Charles, IL 60174-3404

**Catalog Number Selection (Open Components)**

Table 1. *IT*. Electro-Mechanical Catalog Numbering System

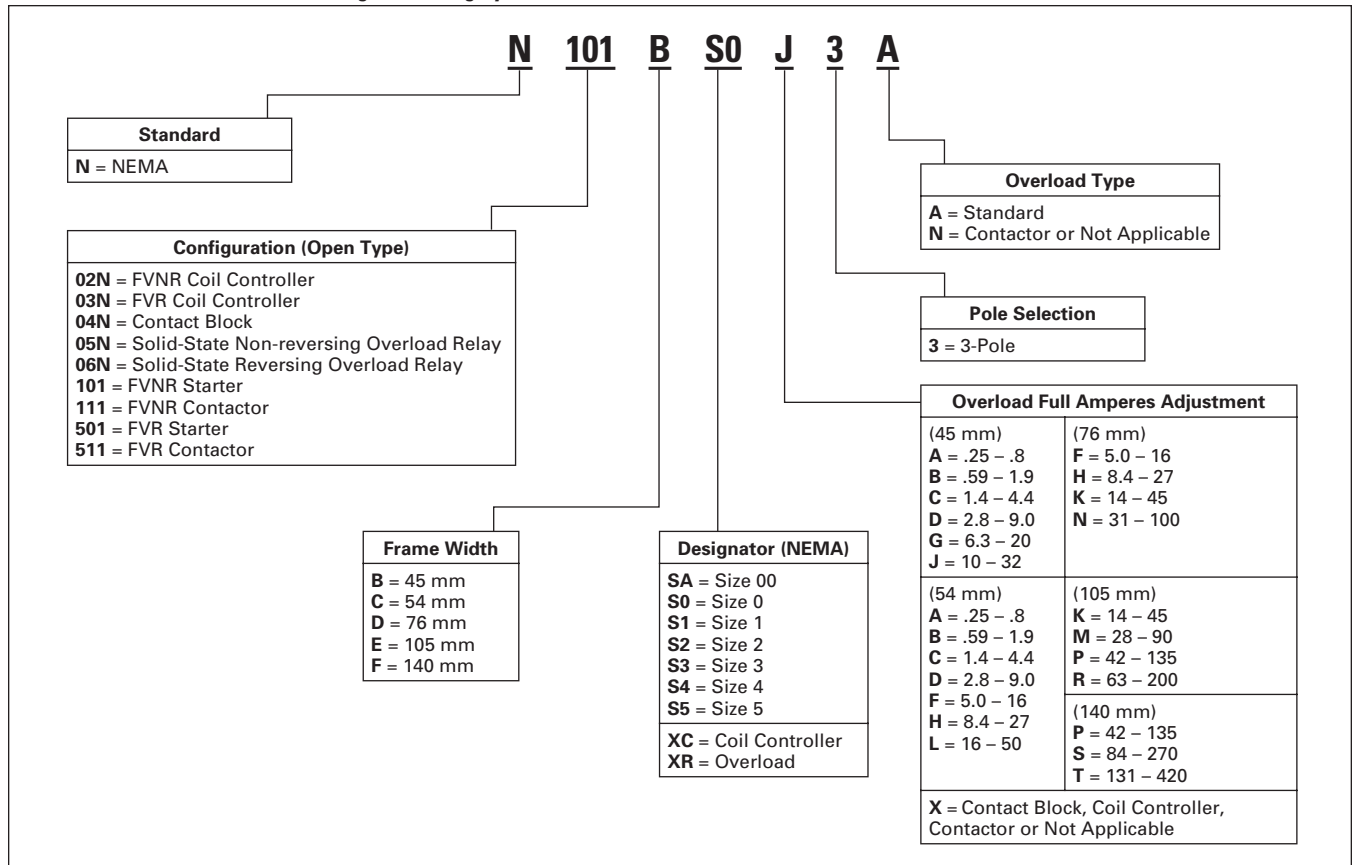

**Note:** When using the Catalog Numbering System for Eaton's Cutler-Hammer *IT*. Electro-Mechanical products, care should be exercised to assure that the Catalog Number for the Overload Relay aligns with the *IT*. Contact Block selected for type, frame size and ampacity, if purchased as separate components.

**Examples:**

- N101BS0J3A — Full Voltage Non-reversing, Size 0 Starter with a 10 – 32 amp overload range
- N111FS5X3N — Full Voltage Non-reversing, Size 5 Contactor
- N501DS2K3A — Full Voltage Reversing Starter with a 14 – 45 amp overload range
- N02NCXCXNN — Coil Controller 54 mm
- N04NBSAX3N — Contact Block Size 00

## Contents

<i>Description</i>	<i>Page</i>
<b>Product Family Overview</b>	
Product Description . . . . .	2
Standards and Certifications . . . . .	2
Catalog Number Selection . . . . .	3
<b>Contactors — Non-reversing and Reversing</b>	
Product Description . . . . .	4
Features . . . . .	4
Product Selection . . . . .	5
<b>Technical Data</b> . . . . .	10
<b>Accessories</b> . . . . .	13
Auxiliary Contacts . . . . .	15
<b>Dimensions</b> . . . . .	18



**NEMA Full Voltage Non-reversing Contactor, Size 0, Cat. No. N111BS0X3N**

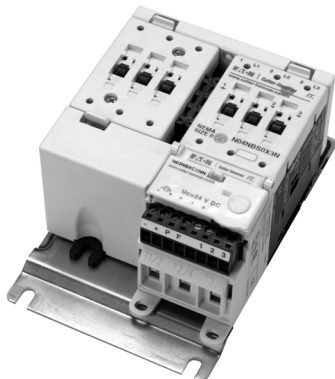

**NEMA Full Voltage Reversing Contactor, Size 0, Cat. No. N511BS0X3N**

## Product Description

The Cutler-Hammer Intelligent Technologies (IT.) Electro-Mechanical Contactor by Eaton Corporation consists of an IT. Electro-Mechanical Contact Block and IT. Electro-Mechanical Coil Controller as a Full Voltage Non-reversing (FVNR) or Full Voltage Reversing (FVR) device. Size 00 to Size 4 Contact Blocks combined with Coil Controllers (factory or field assembled) are stand-alone Contactors. Only the Size 5 Contactors have internal factory assembled coil controllers.

## Features

- Size 00 – 5, 9 – 270A, 2 – 200 hp, 600V
- 24V DC Coil Control — safe, reliable global standard
- Frame width (mm): 45, 54, 76, 105, 140
- No laminations, shading coils or magnet noise
- -40 to 149°F (-40 to 65°C) operating temperature
- No seal in auxiliary contacts required — control wiring is not needed between the contactor and overload relay
- Conformal coated printed circuit boards for resistance to harsh environments
- Unique Pulse Width Modulated coil controller minimizes coil power consumption
- Microprocessor-based control
- Easily accessible mounting feet for panel mounting
- Meets or exceeds global standards for EMC (Electromagnetic compatibility) immunity and emissions
- Front and side mounted Auxiliary Contacts: 1NO, 1 NC, 2NO, 2NC, 1NO/1NC and logic level

- 2- or 3-wire control
- Built-in logic to provide either 2- or 3-wire control, eliminating the need to provide and wire auxiliary contacts to seal in and interlock the contactor coils
- Easy field assembly of control wiring — plug and unplug lockable control connector
- DIN rail mounting for Sizes 00 – 2
- Optional mounting plates for Size 00 – 4
- Common accessories
- Long-life silver nickel and silver tin oxide contacts provide excellent conductivity and superior resistance to welding and arc erosion
- Environmentally friendly materials
- Low wattage coils and minimal heat dissipation

## Reversing Contactors

- Includes Reversing Power Wiring and bus bars
- Mounting plates for Size 00 – 4
- Exclusive internal electronic interlock for reversing
- Field installed Reversing Kits
- Unique coil controller energizes both forward and reverse contactors — one control point for wiring

**Product Selection**

**Non-reversing Contactors**

**When Ordering Specify**

NEMA Size, Continuous Ampere Rating, Voltage, kW/hp and Non-reversing or Reversing

**Note:**

- An **N111** (Size 00 – 4) consists of an **N04N** (Contact Block) and an **N02N** (Coil Controller), factory assembled.
- An **N111F** (Size 5) has an internal coil controller, factory assembled.



Cat. No. N111BS0X3N

**Table 2. Full Voltage 3-Pole DC-Operated Non-reversing Contactors ①**

NEMA Size	Continuous Ampere Rating	Max. UL Horsepower (hp) 60 Hz						Max. UL Horsepower (hp) 50 Hz	3-Pole Non-reversing	
		1-Phase		3-Phase				3-Phase	Catalog Number	Price U.S. \$
		115V	230V	200V/ 208V	230V/ 240V	460V/ 480V	575V/ 600V	380V		
00	9	1/3	1	1-1/2	1-1/2	2	2	1-1/2	N111BSAX3N	170.
0	18	1	2	3	3	5	5	5	N111BS0X3N	214.
1	27	2	3	7-1/2	7-1/2	10	10	10	N111CS1X3N	250.
2	45	3	7-1/2	10	15	25	25	25	N111DS2X3N	454.
3	90	7-1/2	15	25	30	50	50	50	N111ES3X3N	740.
4	135	—	—	40	50	100	100	75	N111ES4X3N	1,765.
5	270	—	—	75	100	200	200	150	N111FS5X3N	3,825.

① 24V DC coil voltage.

**Note:**

- If required, accessories are available on **Page 13**.
- Integral solid-state auxiliary hold-in circuit.
- See **Table 7** for 24V DC power supply requirements.
- Control inputs are rated 24V DC (3 – 5 mA).

Accessories ..... **Pages 13 – 17**  
 Technical Data ..... **Pages 10 – 12**  
 Dimensions ..... **Pages 18 – 21**  
 Discount Symbol ..... **1CD1**

### Contactors — Full Voltage, Non-reversing and Reversing

## Reversing Contactors

### When Ordering Specify

NEMA Size, Continuous Ampere Rating, Voltage, kW/hp, and Non-reversing or Reversing

### Note:

- An **N511** (Size 00 – 4) consists of two **N04N** (Contact Blocks), an **N03N** (FVR Coil Controller), Mechanical Interlock, Fanning Strips and Mounting Plate, factory assembled.
- An **N511F** (Size 5) consists of two **N111F** (Contactors), an Internal Reversing Coil Controller, Mechanical Interlock, Crossover Bus Bars and Wiring Harness, factory assembled.



Cat. No. N511BS0X3N

Table 3. Full Voltage 3-Pole DC-Operated Reversing Contactors ①

NEMA Size	Continuous Ampere Rating	Max. UL Horsepower (hp) 60 Hz						Max. UL Horsepower (hp) 50 Hz	3-Pole Reversing	
		1-Phase		3-Phase					3-Phase	Catalog Number
		115V	230V	200V/ 208V	230V/ 240V	460V/ 480V	575V/ 600V	380V		
00	9	1/3	1	1-1/2	1-1/2	2	2	1-1/2	N511BSAX3N	440.
0	18	1	2	3	3	5	5	5	N511BS0X3N	530.
1	27	2	3	7-1/2	7-1/2	10	10	10	N511CS1X3N	610.
2	45	3	7-1/2	10	15	25	25	25	N511DS2X3N	1,155.
3	90	7-1/2	15	25	30	50	50	50	N511ES3X3N	1,905.
4	135	—	—	40	50	100	100	75	N511ES4X3N	4,725.
5	270	—	—	75	100	200	200	150	N511FS5X3N	8,510.

① 24V DC coil voltage.

### Note:

- If required, accessories are available on **Page 13**.
- Integral solid-state auxiliary hold-in circuit.
- See **Table 7** for 24V DC power supply requirements.
- Control inputs are rated 24V DC (3 – 5 mA).

Accessories .....	<b>Pages 13 – 17</b>
Technical Data .....	<b>Pages 10 – 12</b>
Dimensions .....	<b>Pages 18 – 21</b>
Discount Symbol .....	<b>1CD1</b>

**Contents**

<i>Description</i>	<i>Page</i>
<b>Product Family Overview</b>	
Product Description . . . . .	2
Standards and Certifications . . . . .	2
Catalog Number Selection . . . . .	3
<b>Starters — Non-reversing and Reversing</b>	
Product Description . . . . .	7
Features . . . . .	7
Product Selection . . . . .	8
<b>Technical Data</b> . . . . .	<b>10</b>
<b>Accessories</b> . . . . .	<b>13</b>
Auxiliary Contacts . . . . .	15
<b>Dimensions</b> . . . . .	<b>22</b>



**NEMA Full Voltage Non-reversing Starter, Size 0**



**NEMA Full Voltage Reversing Starter, Size 0**

**Product Description**

The Cutler-Hammer Intelligent Technologies (IT.) Electro-Mechanical Starter by Eaton Corporation consists of an IT. Electro-Mechanical Contact Block or Contactor and IT. Electro-Mechanical Solid-State Overload Relay as a Full Voltage Non-reversing (FVNR) or Full Voltage Reversing (FVR) device. Size 00 to Size 5 Starters are factory or field assembled.

**Features**

- 24V DC control power — safe, reliable global standard
- Unique Pulse Width Modulated (PWM) coil controller minimizes coil power consumption
- Microprocessor based control
- Phase loss and current unbalance protection, user selectable
- Standard selectable Trip Class 10, 20 (factory default) or 30 — no individual part numbers — no programming software
- Ambient compensated overload
- Motor temperature and power-up protection with thermal memory
- Front and side mounted Auxiliary Contacts: 1NO, 1NC, 2NO, 2NC, 1NO/1NC and logic level (1NO/1NC)
- Easily accessible mounting feet for panel mounting
- LED status indication — trip, trip class, motor thermal state, reset, overload state
- Unique “Alarm without Trip” option for critical must run applications
- Lockable overload cover protects against unauthorized adjustment and reset functions

- No control wiring needed between contactor and overload relay — eliminates seal in auxiliary contacts
- Minimal heat — no full voltage coils
- -40° to 149°F (-40° – 65°C) operating temperature
- Wide 3.2:1 current adjustment range
- Exclusive internal 24-bit floating point math calculations with RMS calibrated current measurement
- Meets or exceeds global standards for EMC (Electromagnetic compatibility) immunity and emissions
- IP20 Finger Protection
- Motor running thermal utilization indication
- Manual, Automatic or Remote Reset
- Easy field assembly of control wiring — plug and unplug lockable control connector
- DIN rail mountable, Size 00 – 2
- Communication Interface with Starter Network Adapter Product (SNAP)
- 2- or 3-wire control
- Solid-state alarm output indication
- Optional mounting plates with “Ease of Installation” slotted hole design
- Type 2 Coordination
- Conformal coated printed circuit boards for resistance to harsh environments

**Reversing Starters**

- Includes Reversing Power Wiring and bus bars
- Mounting plates for Size 00 – 4
- Built-in electronic interlock for FVR units
- Unique overload board energizes both forward and reverse starters — one control point for wiring



### Starters — Full Voltage, Non-reversing and Reversing

## Product Selection

### Non-reversing Starters

#### When Ordering Specify

NEMA Size, Continuous Ampere Rating, Voltage, kW/hp, Non-reversing or Reversing and Overload Adjustment Range (Amperes)

#### Note:

- An **N101** (00 – 4) consists of an **N04N** (Contact Block) and an **N05N** (Non-reversing Overload Relay), factory assembled.
- An **N101** (Size 5) consists of an **N111F** (Contactor) and an **N05N** (Non-reversing Overload Relay), factory assembled.



Cat. No. N101BS0G3A

Table 4. Full Voltage Non-reversing DC-Operated, Open Type Starters (Size 00 – 5),<sup>①</sup> with 3-Pole Solid-State Overload Protection

NEMA Size	Continuous Ampere Rating	Overload Adjustment Range (Amperes)	Max. UL Horsepower (hp) 60 Hz						Max. UL Horsepower (hp) 50 Hz	3-Pole Non-reversing		
			1-Phase		3-Phase					3-Phase	Catalog Number	Price U.S. \$
			115V	230V	200V/208V	230V/240V	460V/480V	575V/600V				
00	9	.25 – .8 .59 – 1.9 1.4 – 4.4 2.8 – 9.0 6.3 – 20	1/3	1	1-1/2	1-1/2	2	2	1-1/2	N101BSAA3A N101BSAB3A N101BSAC3A N101BSAD3A N101BSAG3A	206. 206. 206. 206. 206.	
0	18	.25 – .8 .59 – 1.9 1.4 – 4.4 2.8 – 9.0 6.3 – 20 10 – 32	1	2	3	3	5	5	5	N101BS0A3A N101BS0B3A N101BS0C3A N101BS0D3A N101BS0G3A N101BS0J3A	257. 257. 257. 257. 257. 257.	
1	27	.25 – .8 .59 – 1.9 1.4 – 4.4 2.8 – 9.0 5.0 – 16 8.4 – 27 16 – 50	2	3	7-1/2	7-1/2	10	10	10	N101CS1A3A N101CS1B3A N101CS1C3A N101CS1D3A N101CS1F3A N101CS1H3A N101CS1L3A	297. 297. 297. 297. 297. 297. 297.	
2	45	5.0 – 16 8.4 – 27 14 – 45 31 – 100	3	7-1/2	10	15	25	25	25	N101DS2F3A N101DS2H3A N101DS2K3A N101DS2N3A	540. 540. 540. 540.	
3	90	14 – 45 28 – 90 42 – 135	7-1/2	15	25	30	50	50	50	N101ES3K3A N101ES3M3A N101ES3P3A	880. 880. 880.	
4	135	14 – 45 28 – 90 42 – 135 63 – 200	—	—	40	50	100	100	75	N101ES4K3A N101ES4M3A N101ES4P3A N101ES4R3A	1,985. 1,985. 1,985. 1,985.	
5	270	42 – 135 84 – 270 131 – 420	—	—	75	100	200	200	150	N101FS5P3A N101FS5S3A N101FS5T3A	4,845. 4,845. 4,845.	

<sup>①</sup> 24V DC coil voltage.

#### Note:

- If required, accessories are available on **Page 13**.
- The standard **IT** starter is for 3-phase applications only.
- See **Table 7** for 24V DC power supply requirements.
- Control inputs are rated 24V DC (3 – 5 mA).

Accessories ..... **Pages 13 – 17**  
 Technical Data ..... **Pages 10 – 12**  
 Dimensions ..... **Pages 22 – 24**  
 Discount Symbol ..... **1CD1**



September 2003

Starters — Full Voltage, Non-reversing and Reversing

**Reversing Starters**

**When Ordering Specify**

NEMA Size, Continuous Ampere Rating, Voltage, kW/hp, Non-reversing or Reversing and Overload Adjustment Range (Amperes)

**Note:**

- An **N501** (Size 00 – 4) consists of two **N04N** (Contact Blocks), **N06N** (Reversing Overload Relay), Fanning Strips, Mechanical Interlock and Mounting Plate, factory assembled.
- An **N501F** (Size 5) consists of two **N111F** (Contactors), **N06N** (Reversing Overload Relay), Fanning Strips, Mechanical Interlock, Crossover Bus Bars and Reversing Wiring Harness, factory assembled.



Cat. No. N501BS0G3A

**Table 5. Full Voltage Reversing DC-Operated, Open Type Starters (Size 00 – 5), ① with 3-Pole Solid-State Overload Protection**

NEMA Size	Continuous Ampere Rating	Overload Adjustment Range (Amperes)	Max. UL Horsepower (hp) 60 Hz						Max. UL Horsepower (hp) 50 Hz	3-Pole Reversing	
			1-Phase		3-Phase					3-Phase 380V	Catalog Number
			115V	230V	200V/208V	230V/240V	460V/480V	575V/600V			
00	9	.25 – .8 .59 – 1.9 1.4 – 4.4 2.8 – 9.0 6.3 – 20	1/3	1	1-1/2	1-1/2	2	2	1-1/2	N501BSAA3A N501BSAB3A N501BSAC3A N501BSAD3A N501BSAG3A	491. 491. 491. 491. 491.
0	18	.25 – .8 .59 – 1.9 1.4 – 4.4 2.8 – 9.0 6.3 – 20 10 – 32	1	2	3	3	5	5	5	N501BS0A3A N501BS0B3A N501BS0C3A N501BS0D3A N501BS0G3A N501BS0J3A	585. 585. 585. 585. 585. 585.
1	27	.25 – .8 .59 – 1.9 1.4 – 4.4 2.8 – 9.0 5.0 – 16 8.4 – 27 16 – 50	2	3	7-1/2	7-1/2	10	10	10	N501CS1A3A N501CS1B3A N501CS1C3A N501CS1D3A N501CS1F3A N501CS1H3A N501CS1L3A	665. 665. 665. 665. 665. 665. 665.
2	45	5.0 – 16 8.4 – 27 14 – 45 31 – 100	3	7-1/2	10	15	25	25	25	N501DS2F3A N501DS2H3A N501DS2K3A N501DS2N3A	1,255. 1,255. 1,255. 1,255.
3	90	14 – 45 28 – 90 42 – 135	7-1/2	15	25	30	50	50	50	N501ES3K3A N501ES3M3A N501ES3P3A	2,065. 2,065. 2,065.
4	135	14 – 45 28 – 90 42 – 135 63 – 200	—	—	40	50	100	100	75	N501ES4K3A N501ES4M3A N501ES4P3A N501ES4R3A	5,040. 5,040. 5,040. 5,040.
5	270	42 – 135 84 – 270 131 – 420	—	—	75	100	200	200	150	N501FS5P3A N501FS5S3A N501FS5T3A	9,680. 9,680. 9,680.

① 24V DC coil voltage.

**Note:**

- If required, accessories are available on **Page 13**.
- The standard **IT** starter is for 3-phase applications only.
- See **Table 7** for 24V DC power supply requirements.
- Control inputs are rated 24V DC (3 – 5 mA).

Accessories ..... **Pages 13 – 17**  
 Technical Data ..... **Pages 10 – 12**  
 Dimensions ..... **Pages 22 – 24**  
 Discount Symbol ..... **1CD1**

### Technical Data and Specifications

**Table 6. Specifications**

Description	Size 00, 0	Size 1	Size 2	Size 3, 4	Size 5
<b>Overall Dimensions in Inches (mm) <sup>①</sup> — w x h x d</b>					
Non-reversing Contactor	1.8 x 4.4 x 2.4 (45 x 111 x 60)	2.1 x 4.4 x 2.4 (54 x 113 x 60)	3.0 x 5.9 x 3.1 (76 x 150 x 79)	4.1 x 8.0 x 3.5 (105 x 203 x 90)	5.6 x 14.0 x 7.0 (142 x 355 x 178)
Reversing Contactor	3.8 x 5.9 x 2.7 (96 x 149 x 69)	4.5 x 5.9 x 2.6 (114 x 149 x 67)	6.2 x 7.4 x 3.3 (158 x 188 x 84)	8.5 x 9.5 x 3.8 (216 x 242 x 97)	11.7 x 17.2 x 7.0 (296 x 436 x 178)
Non-reversing Starter	1.8 x 5.0 x 2.5 (45 x 127 x 63)	2.1 x 5.4 x 2.5 (54 x 138 x 63)	3.0 x 5.9 x 3.1 (76 x 150 x 79)	4.1 x 8.0 x 3.5 (105 x 203 x 90)	5.7 x 19.4 x 7.0 (145 x 492 x 178)
Reversing Starter	3.8 x 5.9 x 2.7 (96 x 149 x 69)	4.5 x 5.9 x 2.6 (114 x 149 x 67)	6.2 x 7.4 x 3.3 (158 x 188 x 84)	8.5 x 9.5 x 3.8 (216 x 242 x 97)	11.8 x 21.0 x 7.0 (300 x 533 x 178)
<b>Mounting Hole Spacing in Inches (mm) — w x h</b>					
Non-reversing Contactor	1.33 x 4.0 (33.8 x 101)	1.46 x 4.10 (37 x 104)	.94 x 2.87 (24 x 73)	1.33 x 4.13 (33.8 x 105)	1.75 x 13.0 (44.5 x 330)
Reversing Contactor	3.15 x 5.35 (80 x 136)	3.15 x 5.35 (80 x 136)	5.51 x 6.89 (140 x 175)	7.87 x 9.06 (200 x 230)	7.82 x 13.0 (198.5 x 330)
Non-reversing Starter	1.33 x 4.62 (33.8 x 117.3)	1.46 x 5.04 (37 x 128)	.94 x 2.87 (24 x 73)	1.33 x 4.13 (33.8 x 105)	1.75 x 18.3 (44.5 x 465)
Reversing Starter	3.15 x 5.35 (80 x 136)	3.15 x 5.35 (80 x 136)	5.51 x 6.89 (140 x 175)	7.87 x 9.06 (200 x 230)	7.82 x 18.3 (198.5 x 465)
<b>Mounting Positions</b>					
Panel-Vertical	Yes	Yes	Yes	Yes	Yes
Panel-Horizontal	Yes	Yes	Yes	Yes	Yes
DIN Rail Mountable	Yes <sup>②</sup>	Yes <sup>②</sup>	Yes <sup>②</sup>	No	No
<b>Weights in Lb. (kg)</b>					
Non-reversing Contactor	.7 (.31)	.9 (.42)	2.8 (1.27)	6.7 (3.05)	20.0 (9.1)
Reversing Contactor	1.9 (.86)	2.6 (1.17)	6.9 (3.13)	16.9 (7.67)	48.0 (21.8)
Non-reversing Starter	.9 (.40)	1.2 (.53)	2.9 (1.32)	7.1 (3.20)	27.0 (12.3)
Reversing Starter	2.0 (.90)	2.6 (1.20)	7.1 (3.20)	16.8 (7.60)	55.0 (25.0)
<b>Mechanical Operating Rate <sup>③</sup></b>					
Maximum	3/sec	3/sec	2/sec	2/sec	1/sec
<b>Mechanical Life</b>					
	10,000,000	10,000,000	8,000,000	8,000,000	5,000,000
<b>Humidity <sup>④</sup></b>					
	95% Non-condensing	95% Non-condensing	95% Non-condensing	95% Non-condensing	95% Non-condensing
<b>Insulation Voltage (Ui)</b>					
	690V	690V	690V	690V	690V
<b>Impulse Withstand Voltage (Uimp)</b>					
	6 kV	6 kV	6 kV	6 kV	6 kV

<sup>①</sup> Auxiliaries add approximately 1.0" (25 mm) to depth for single, 1.2" (30 mm) for dual.

<sup>②</sup> Non-reversing contactors and starters only.

<sup>③</sup> No load condition.

<sup>④</sup> Up to 99% humidity depending on application. Consult factory.

September 2003

## Technical Data and Specifications

Table 6. Specifications, continued

Description	Size 00, 0	Size 1	Size 2	Size 3, 4	Size 5
<b>Finger Protection</b>					
Front	IP20	IP20	IP20	IP20	IP20
At Terminals	IP10	IP10	IP00	IP00	IP00
At Terminals with max. size wire installed	IP20	IP10	IP10	IP00	IP00
<b>Terminals L1, L2, L3/T1, T2, T3</b> ①					
1 Wire per Terminal (stranded or solid)	14 – 8 AWG (1.5 – 10 mm <sup>2</sup> )	14 – 4 AWG (1.5 – 16 mm <sup>2</sup> )	14 – 1 AWG (1.5 – 35 mm <sup>2</sup> )	6 – 250 MCM (16 – 120 mm <sup>2</sup> )	4 – 750 MCM (25 – 420 mm <sup>2</sup> )
2 Wires per Terminal (stranded or solid)	14 – 10 AWG (1.5 – 4 mm <sup>2</sup> )	14 – 6 AWG (1.5 – 16 mm <sup>2</sup> )	14 – 2 AWG (1.5 – 25 mm <sup>2</sup> )	6 – 3/0 AWG (16 – 70 mm <sup>2</sup> )	1/0 – 300 MCM (50 – 150 mm <sup>2</sup> )
Strip Length	.45" (11 mm)	.5" (12 mm)	.7" (18 mm)	.8" (21 mm)	1.5" (40 mm)
Torque (max.)	20 lb-in (2.2 Nm) for 14 – 10 AWG (1.5 – 6 mm <sup>2</sup> ); 25 lb-in (2.8 Nm) for 8 AWG (10 mm <sup>2</sup> )	35 lb-in (4.0 Nm) for 14 – 10 AWG (1.5 – 6 mm <sup>2</sup> ); 40 lb-in (4.5 Nm) for 8 AWG (10 mm <sup>2</sup> ); 45 lb-in (5.0 Nm) for 6 – 4 AWG (16 mm <sup>2</sup> )	45 lb-in (5.0 Nm) for Single 14 – 8 AWG (1.5 – 10 mm <sup>2</sup> ); 100 lb-in (11 Nm) for Single 6 – 1 AWG (16 – 35 mm <sup>2</sup> ) and Dual Wire Combinations	250 lb-in (28 Nm)	550 lb-in (62 Nm)
Driver	2.5 mm Hex Key	3 mm Hex Key	5/32" (4 mm) Hex Key	5/16" (8 mm) Hex Key	5/16" (8 mm) Hex Key
<b>Operation Performance</b>					
Coil Voltage (nominal)	24V DC	24V DC	24V DC	24V DC	24V DC
Coil Operating Voltage Range (V DC)	20 – 28	20 – 28	20 – 28	20 – 28	20 – 28
<b>Control Terminals</b>					
(- and +) 1 Wire per Terminal	14 – 12 AWG (1.5 – 2.5 mm <sup>2</sup> )	14 – 12 AWG (1.5 – 2.5 mm <sup>2</sup> )	14 – 12 AWG (1.5 – 2.5 mm <sup>2</sup> )	14 – 12 AWG (1.5 – 2.5 mm <sup>2</sup> )	14 – 12 AWG (1.5 – 2.5 mm <sup>2</sup> )
(- and +) 2 Wires per Terminal	14 AWG (1.5 mm <sup>2</sup> )	14 AWG (1.5 mm <sup>2</sup> )	14 AWG (1.5 mm <sup>2</sup> )	14 AWG (1.5 mm <sup>2</sup> )	14 AWG (1.5 mm <sup>2</sup> )
(P, F, R, 1, 2, 3) 1 Wire per Terminal	22 – 12 AWG (0.5 – 2.5 mm <sup>2</sup> )	22 – 12 AWG (0.5 – 2.5 mm <sup>2</sup> )	22 – 12 AWG (0.5 – 2.5 mm <sup>2</sup> )	22 – 12 AWG (0.5 – 2.5 mm <sup>2</sup> )	22 – 12 AWG (0.5 – 2.5 mm <sup>2</sup> )
(P, F, R, 1, 2, 3) 2 Wires per Terminal	18 – 14 AWG (0.75 – 1.5 mm <sup>2</sup> )	18 – 14 AWG (0.75 – 1.5 mm <sup>2</sup> )	18 – 14 AWG (0.75 – 1.5 mm <sup>2</sup> )	18 – 14 AWG (0.75 – 1.5 mm <sup>2</sup> )	18 – 14 AWG (0.75 – 1.5 mm <sup>2</sup> )
Torque (max.)	4.5 lb-in (.5 Nm)	4.5 lb-in (.5 Nm)	4.5 lb-in (.5 Nm)	4.5 lb-in (.5 Nm)	4.5 lb-in (.5 Nm)
Strip Length	.25 (7 mm)	.25 (7 mm)	.25 (7 mm)	.25 (7 mm)	.25 (7 mm)
Driver	.13 (3.5 mm) Flat	.13 (3.5 mm) Flat	.13 (3.5 mm) Flat	.13 (3.5 mm) Flat	.13 (3.5 mm) Flat
<b>Temperature</b> ②					
Operating	-40° to +149°F (-40° to +65°C)	-40° to +149°F (-40° to +65°C)	-40° to +149°F (-40° to +65°C)	-40° to +149°F (-40° to +65°C)	-40° to +149°F (-40° to +65°C)
Storage	-58° to +176°F (-50° to +80°C)	-58° to +176°F (-50° to +80°C)	-58° to +176°F (-50° to +80°C)	-58° to +176°F (-50° to +80°C)	-58° to +176°F (-50° to +80°C)
<b>Environmental</b>					
Shock/Vibration	15G/5G	15G/5G	15G/5G	15G/5G	15G/5G ③
Altitude ②	6600 FT (2000M)	6600 FT (2000M)	6600 FT (2000M)	6600 FT (2000M)	6600 FT (2000M)
<b>Pull-In Time (mS) @ 24V</b>					
Excl. Debounce Time	15	15	25	30	70 – 200
Incl. Debounce Time	75	80	88	95	120 – 300
<b>Dropout Time (mS) @ 24V</b>					
Excl. Debounce Time	5	5	12	15	50 – 150
Incl. Debounce Time	65	70	75	80	70 – 250

① Use Class B 75°C copper wire only (or 90°C copper wire sized for 75°C operation per NEC).

② Consult factory for higher ratings.

③ The Non-reversing Starter requires the use of all six mounting screws for the maximum rating.

**Note:** At other temperatures expressed in °C, for either inrush or sealed, use the 20°C value from the table in the following

$$\text{Watts} = W_{20} [1.1 - .005(T)] \text{ and} \\ \text{Amps} = A_{20} [1.1 - .005(T)]$$

For example, inrush requirements for a NEMA Size 2 Starter at -25°C would be:  
Watts = 130 [1.1 - .005 (-25)] = 160  
Amps = 5.4 [1.1 - .005 (-25)] = 6.6

**Notes:**

■ Response time for Control Inputs = Debounce Time

■ The time between operating forward and reverse must be greater than the Debounce Time.

Table 7. 24V DC Power Supply Requirements @ 68°F (20°C) (see Note at left)

Contactor/Starter Size	Sealed In	Inrush		Duration (mS)
		Wattage	Amps	
Catalog Number ④	NEMA Size	Wattage	Amps	Duration (mS)
N_11B_ _X3N	00, 0	3.7	.15	80
N_01B_ _3A	00, 0	3.2	.13	80
N_11C_ _X3N	1	4.2	.18	90
N_01C_ _3A	1	3.6	.15	90
N_ _1D_ _3	2	5.0	.21	130
N_ _1E_ _3	3, 4	5.6	.23	140
N_ _1F_ _3	5	12.0	.50	200
N_01F_ _3_	5	13.0	.54	200

④ \_ indicates missing digit/character of the Catalog Number; may have multiple values.

Technical Data and Specifications

Electrical Life — AC-1, AC-2, AC-3 and AC-4 Utilization Categories

Table 8. Utilization Categories

Category	Typical Application
AC-1	Non-inductive or slightly inductive loads: Resistance furnaces, heating.
AC-2	Slip-ring motors: Starting and stopping of running motors
AC-3	Squirrel cage motors: Starting, switching off motors during running (motors in most industrial applications typically fall into this category).
AC-4	Squirrel cage motors: Starting, plugging ①, inching ② (very few applications in industry are totally AC-4).

① Plugging is stopping or reversing the motor rapidly by reversing the connections while the motor is running.  
 ② Inching or jogging is energizing the motor once or repeatedly for short durations to obtain small movements of the motor driven load.

**Life Load Curves** — Eaton’s Cutler-Hammer 17. Electro-Mechanical Series NEMA contactors have been designed and manufactured for superior life performance. All testing has been based on requirements as found in IEC 60947-4-1 and conducted by us. When selecting a contactor, the specifier must give attention to the specific load, utilization category and the required electrical life. For a definition of Utilization Categories, see **Table 8** above.

**Note:** AC-3 tests are conducted at rated device currents and AC-4 tests are conducted at six-times rated device currents. All tests have been run at 460V, 60 Hz.

Actual application life may vary, depending on environmental conditions and application duty cycle.

**Contactor Choice** —

- Decide what utilization category the application is and choose the appropriate curve from **Figure 1** or **Figure 2**.
- Locate the intersection of the life-load curve with the operational current (Ie) of the application, as found on the horizontal axis.
- Read the estimated contact life along the vertical axis in number of operations.

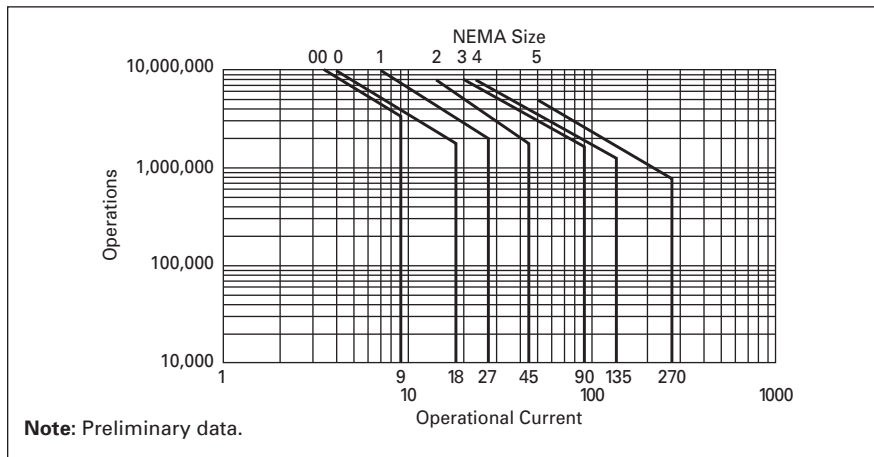

Figure 1. Electrical Life — AC-3 Utilization Category

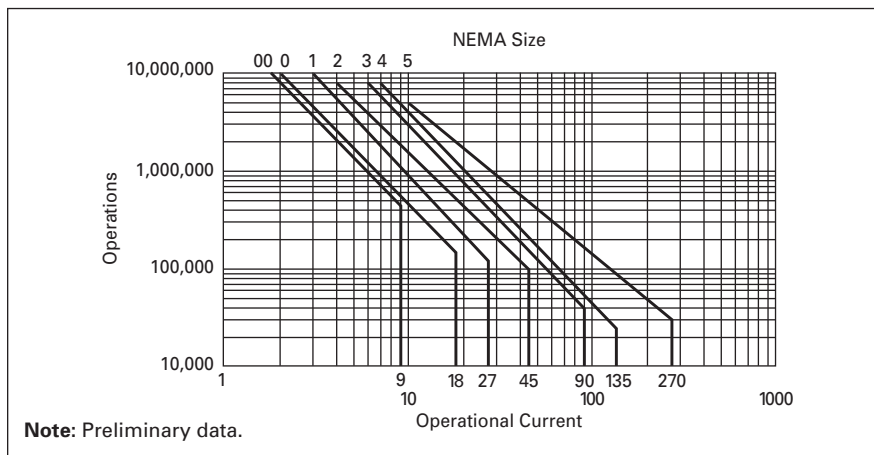

Figure 2. Electrical Life — AC-4 Utilization Category

**Trip Times**

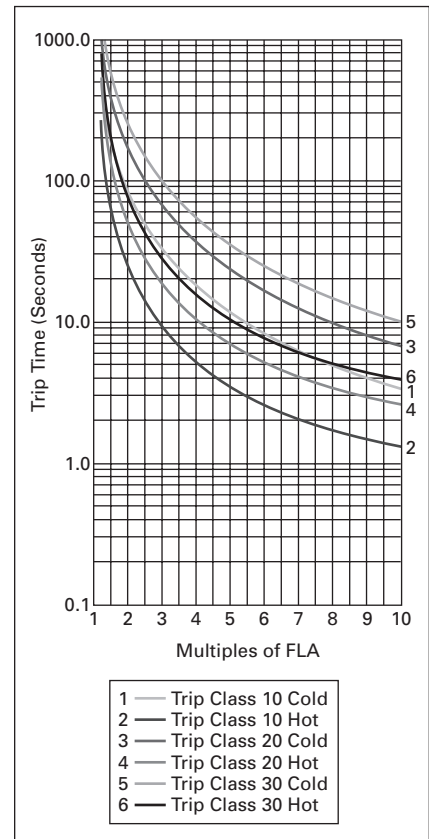

Figure 3. Class 10, 20 and 30 Trip Curves

**Modular Components — Contactor Field Assembly**

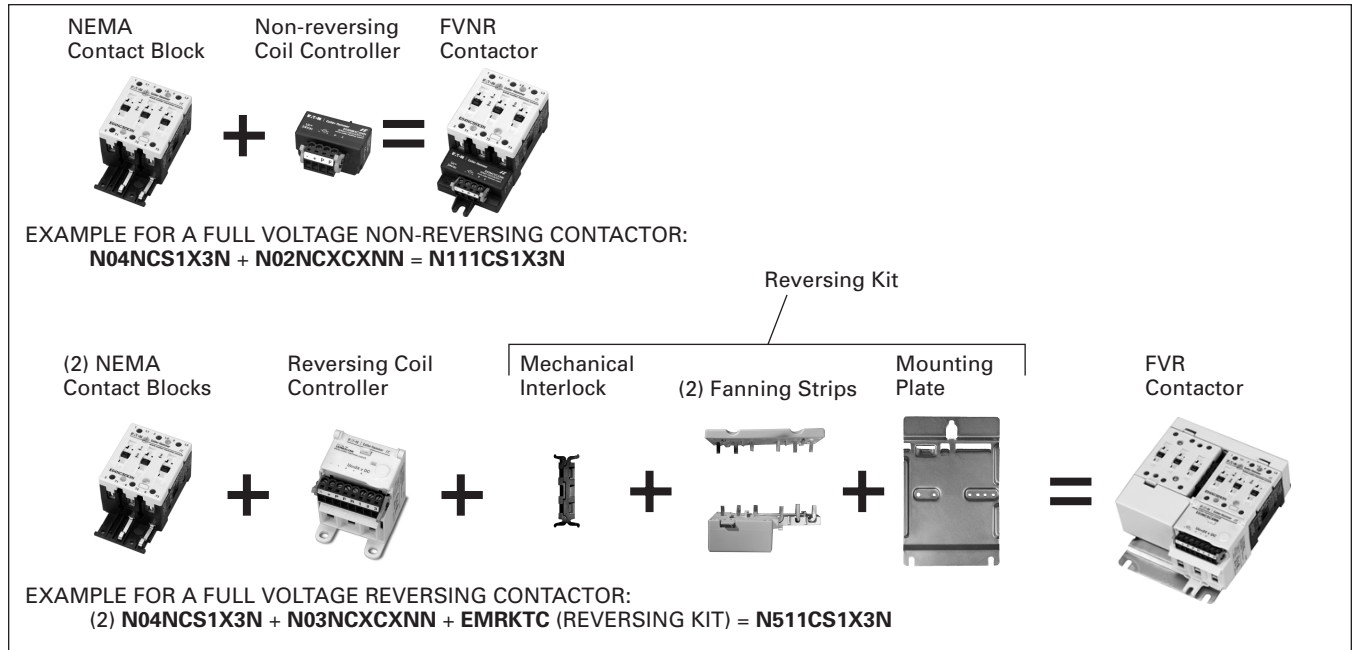

Figure 4. Modular Contactor Assembly

**Modular Components — Starter Field Assembly**

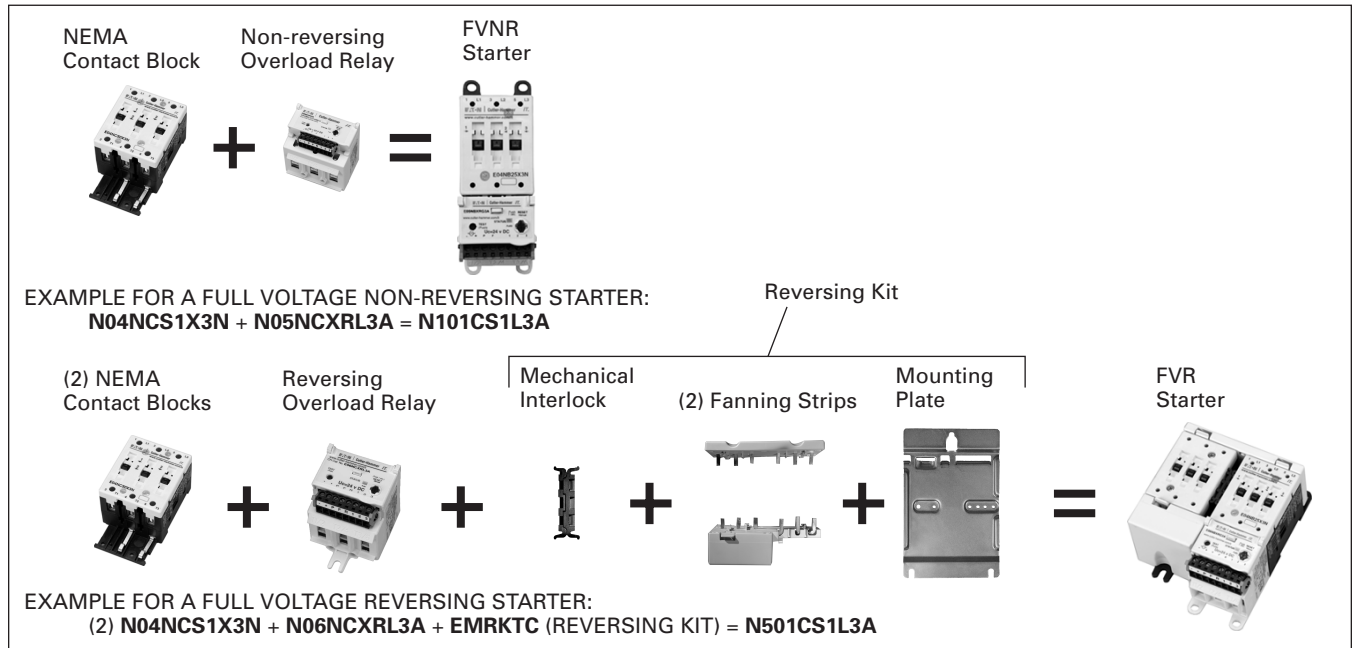

Figure 5. Modular Starter Assembly

Accessories

**NEMA Contact Block**



**Table 9. NEMA Contact Block**

Size	Amperes	Catalog Number	Price U.S. \$
00	9	N04NBSAX3N	153.00
0	18	N04NBS0X3N	198.00
1	27	N04NCS1X3N	223.00
2	45	N04NDS2X3N	418.00
3	90	N04NES3X3N	700.00
4	135	N04NES4X3N	1,780.00

**Note:**

- N04N + N05N = N101; N04N + N02N = N111 (45 – 140 mm)
- N04N + N06N = N501; N04N + N03N = N511 (45 – 140 mm)

**NEMA Solid-State Overload Relay — Non-reversing**



**Table 10. NEMA Solid-State Overload Relay — Non-reversing**

Size	Overload Adjustment Range (Amperes)	Catalog Number	Price U.S. \$
00, 0	.25 – .8	N05NBXRA3A	74.50
	.59 – 1.9	N05NBXRB3A	74.50
	1.4 – 4.4	N05NBXRC3A	74.50
	2.8 – 9.0	N05NBXRD3A	74.50
	6.3 – 20	N05NBXRG3A	74.50
0	10 – 32	N05NBXRJ3A	74.50
1	.25 – .8	N05NCXRA3A	133.00
	.59 – 1.9	N05NCXRB3A	133.00
	1.4 – 4.4	N05NCXRC3A	133.00
	2.8 – 9.0	N05NCXRD3A	133.00
	5.0 – 16	N05NCXRF3A	133.00
	8.4 – 27	N05NCXRH3A	133.00
2	16 – 50	N05NCXRL3A	133.00
	5.0 – 16	N05NDXRF3A	176.00
	8.4 – 27	N05NDXRH3A	176.00
	14 – 45	N05NDXRK3A	176.00
3, 4	31 – 100	N05NDXRN3A	176.00
	14 – 45	N05NEXRK3A	291.00
	28 – 90	N05NEXRM3A	291.00
4	42 – 135	N05NEXRP3A	291.00
	63 – 200	N05NEXRR3A	291.00
5	42 – 135	N05NFXRP3A	984.00
	84 – 270	N05NFXRS3A	984.00
	131 – 420	N05NFXRT3A	984.00

**NEMA Coil Controller**



Size 00-1 Non-reversing (pictured)

**Table 11. NEMA Coil Controller**

Size	Catalog Number	Price U.S. \$
<b>Non-reversing</b>		
00, 0	N02NBXCXNN	25.50
1	N02NCXCXNN	38.25
2	N02NDXCXNN	57.00
3, 4	N02NEXCXNN	76.50
5	EMUCCF	—

Auxiliary Contacts



Auxiliary Contacts are available for mounting on Eaton’s Cutler-Hammer Intelligent Technologies (IT) Electro-Mechanical Contactors and Starters. The various choices available for non-reversing models are shown in **Tables 12 and 13**, and their ratings in **Tables 14 – 16**. For reversing models, the number of auxiliaries indicated is for each of the contactors/starters in the assembly.

**Table 12. Auxiliary Contact Availability — Sizes 00 – 5**

Top Mounted (Maximum Auxiliaries per Contactor/Starter) ②						Contact Type	Catalog Number	Price U.S. \$
Contactor/Starter Size								
Size 00, 0	Size 1	Size 2	Size 3, 4	Size 5				
3	3	3	3	—	1NO	EMA13	21.70	
3	3	3	3	—	1NC	EMA14	21.70	
2	2 ①	3	3	—	1NO-1NC	EMA15	29.00	
2	2 ①	3	3	—	2NO	EMA16	29.00	
2	2 ①	3	3	—	2NC	EMA17	29.00	
2	3	3	3	3	Logic Level 1NO-1NC	EMA70	34.25	

① Other combinations: Single, Dual, Single; Dual, Single, Dual; and Dual, Logic Level, Dual  
② For reversers, multiply quantities by two.

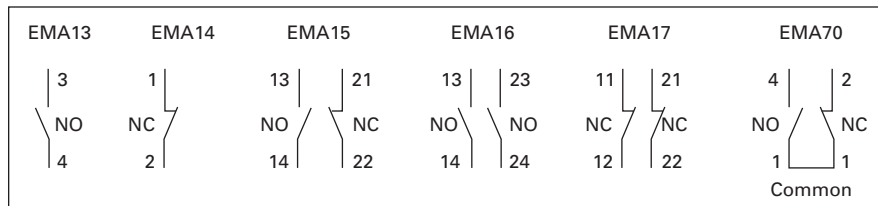

**Figure 6. Connecting Diagram — Sizes 00 – 5**

**Table 13. Auxiliary Contact — Size 5**

Auxiliary Contacts per Non-reversing and Reversing Contactor or Starter				
Max	Contact Type	Description	Catalog Number	Price U.S. \$
2	1NO	Base auxiliary (max. 1 per side)	C320KGS41	45.50
2	1NO-1NC	Base auxiliary (max. 1 per side)	C320KGS42	61.50
6	1NO	C320KGS41 or C320KGS42 required (max. 3 Add-on auxiliaries per side)	C320KGS20	45.50
2	1NO Logic Level	C320KGS41 or C320KGS42 required (max. 1 Add-on auxiliary per side)	C320KGS20L ③	—
6	1NC	C320KGS41 or C320KGS42 required (max. 2 Add-on auxiliaries per side)	C320KGS21	45.50
2	1NC Logic Level	C320KGS41 or C320KGS42 required (max. 1 Add-on auxiliary per side)	C320KGS21L ③	—
2	1NO-1NC	C320KGS41 or C320KGS42 required (max. 1 Add-on auxiliary per side)	C320KGS22	61.50
2	1NO-1NC Logic Level	C320KGS41 or C320KGS42 required (max. 1 Add-on auxiliary per side)	C320KGS22L ③	—
3	1NO-1NC Logic Level	Front mounted only	EMA70 ④	34.25

③ Contact factory for availability. ④ For reversers, multiply quantities by two.

**Notes:**

- Side Mounted — Maximum (10) Total Circuits
- Front Mounted — Maximum (6) Total Circuits ④
- Maximum 4 auxiliaries per side (base + 3 side mounted)
- EMASA/B \_ \_ have been superseded by the above Catalog Numbers.

**Table 14. IEC Ratings**

DC-13		AC-15	
U <sub>e</sub> Voltage	I <sub>e</sub> Amps.	U <sub>e</sub> Voltage	I <sub>e</sub> Amps.
24	5	48	8
48	2.5	120	6
125	1.1	240	4
250	.55	440	2

**Table 15. NEMA A600 Ratings**

Current	AC Voltage			
	120	240	480	600
Make and Interrupting	60	30	15	12
Break	6	3	1.5	1.2
Continuous	10	10	10	10
Thermal	10	10	10	10

**Table 16. NEMA P300 Ratings**

Current	DC Voltage	
	125	250
Make and Interrupting	1.1	.55
Break	1.1	.55
Continuous	5	5
Thermal	5	5

**Table 17. EMA70 Auxiliary Contact**

DC-12		AC-12	
U <sub>e</sub>	I <sub>e</sub>	U <sub>e</sub>	I <sub>e</sub>
30	.1	250	.1



### Accessories — DSNAP

## DeviceNet Starter Network Adapter Product (DSNAP)

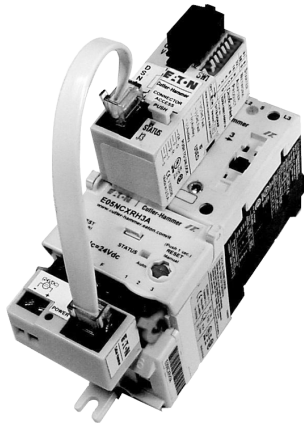

Catalog Number D77B-DSNAP  
with 54 mm IT. Starter

The DeviceNet Starter Network Adapter Product (DSNAP) is a front-mount device that serves as a single node on DeviceNet, providing communication capability, control and monitoring to Eaton's Cutler-Hammer Intelligent Technologies (IT.) Electro-mechanical Starters, as well as the S751 Soft Start, as listed in Tables 18 – 19.

When HAND/OFF/AUTO is required, the HOA option will allow for the connection of hard wired operators. This option allows for Hand Control even if the DSNAP is not connected.

The product greatly increases the functionality of the IT. Electromechanical Starter and S751 Soft Start with the addition of enhanced features.

The IT. DSNAP is designed for use with the same 24V DC power as the starter. A starter power sensing circuit indi-

cates to the user that the starter does not have 24V DC power, signaling a fault or an E-Stop.

### General Features

- Communication to DeviceNet consuming one DeviceNet MAC ID
- Manually set MAC ID and baud rate; configuration using a software application is not required for normal operation
- Advanced configuration using CH Studio software
- Includes pre-wired starter interconnect cable and terminal adapter

### Comprehensive Motor Data and Control

- RMS average current
- % of operating FLA
- % thermal memory
- Integral contact position detection
- Operating status and fault codes
- At speed (soft starters)
- START/STOP control
- RUN/FORWARD-REVERSE control
- Trip Reset

### Extended Starter Capabilities

- Ground fault detection (with accessory)
- Fault log
- Current level warning (adjustable)
- Underload warning (adjustable)

### Approvals (Pending)

- UL508
- CE
- CSAC22.2 No. 14-95

Table 18. NEMA SNAP Connectivity

NEMA N101, N501	
Size	Continuous Ampacity Rating
00	9
0	18
1	27
2	45
3	90
4	135
5	270

Table 19. S751 SNAP Connectivity

S751 Soft Start	
54 mm	All Sizes

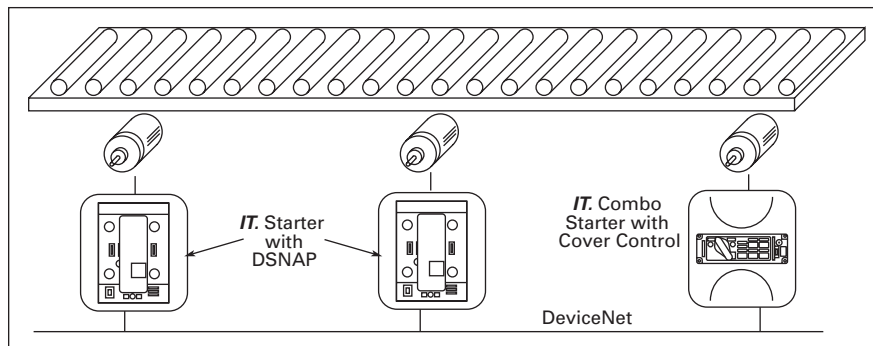

Figure 7. Typical DSNAP Application

### Application

In a typical application, the DSNAP front mounts to an IT. starter or soft start. The DSNAP connects directly to DeviceNet, allowing for control and monitoring of the starter/soft start. A PC or PLC serves as the central control and scans the DSNAP for motor control and monitoring information.

**Table 20. DeviceNet Specifications**

<b>DeviceNet Connections</b>	<b>Group 2 Master Slave Connection Set</b> Polling Bit Strobe Explicit No UCMM
DeviceNet Baud Rate	125K, 250K, 500K

**Table 21. DSNAP Specifications**

Description	Specifications
<b>Transportation/Storage</b>	
Temperature	-58° to 176°F (-25° to 80°C)
Humidity	0 – 95% non-condensing
<b>Operating</b>	
Temperature	-13° to 131°F (-25° to 55°C)
Humidity	0 – 95% non-condensing
Altitude	Above 2000 meters (6600 feet) consult factory
Shock	15 g's half-wave sinusoidal 11 msecs
Vibration	5 – 57.5 Hz (100 – 17 msecs) @ .3 mm SA 57.5 – 150 Hz (17 – 6.7 msecs) @ .35 mm SA
Pollution Degree	3
Enclosure	IP20

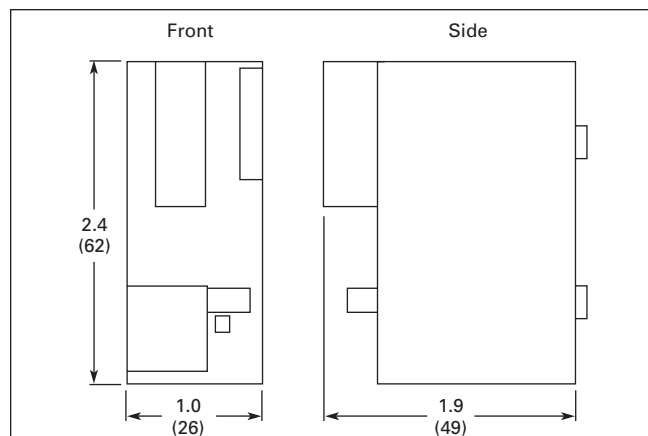

**Figure 8. DSNAP Approximate Dimensions in Inches (mm)**

**Table 22. Product Selection**

Description	Catalog Number	Price U.S. \$
DSNAP Kit with TC8, RJJ1 and DSNAP FVNR	<b>D77B-SNAP-X1</b>	275.00
DSNAP Kit with TC8, RJJ1, Second Aux. and DSNAP FVR	<b>D77B-SNAP-X2</b>	320.10
DSNAP Kit with TC8, RJJ1 and DSNAP FVNR HOA	<b>D77B-SNAP-X3</b>	350.53
DSNAP Kit with TC8, RJJ1, Second Aux. and DSNAP FVR HOA	<b>D77B-SNAP-X4</b>	377.82

**Dimensions**

**Non-reversing Contactors (Sizes 00 – 1)**

**Table 23. Approximate Dimensions in Inches (mm)**

NEMA Size	Overall					Mounting Holes				Req. Mtg. Screws	Terminals		
	Width	Height	Depth	Depth w/ Auxiliary	Depth added w/ DIN Rail	Width	Height	Mtg. Hole to Top	DIN Rail to Top		Control	Line	Load
	A	B	C	D	E	F	G	H	J		P	Q	R
00, 0	1.8 (45)	4.4 (111)	2.4 (60)	3.6 (91)	.1 (3)	1.33 (33.8)	4.0 (101)	.2 (5)	.9 (23)	(3) #8 M4	.7 (19)	1.2 (30)	1.2 (30)
1	2.1 (54)	4.45 (113)	2.4 (60)	3.6 (91)	.1 (3)	1.46 (37)	4.1 (104)	.2 (5)	.8 (20)	(3) #8 M4	.7 (19)	1.2 (30)	1.2 (30)

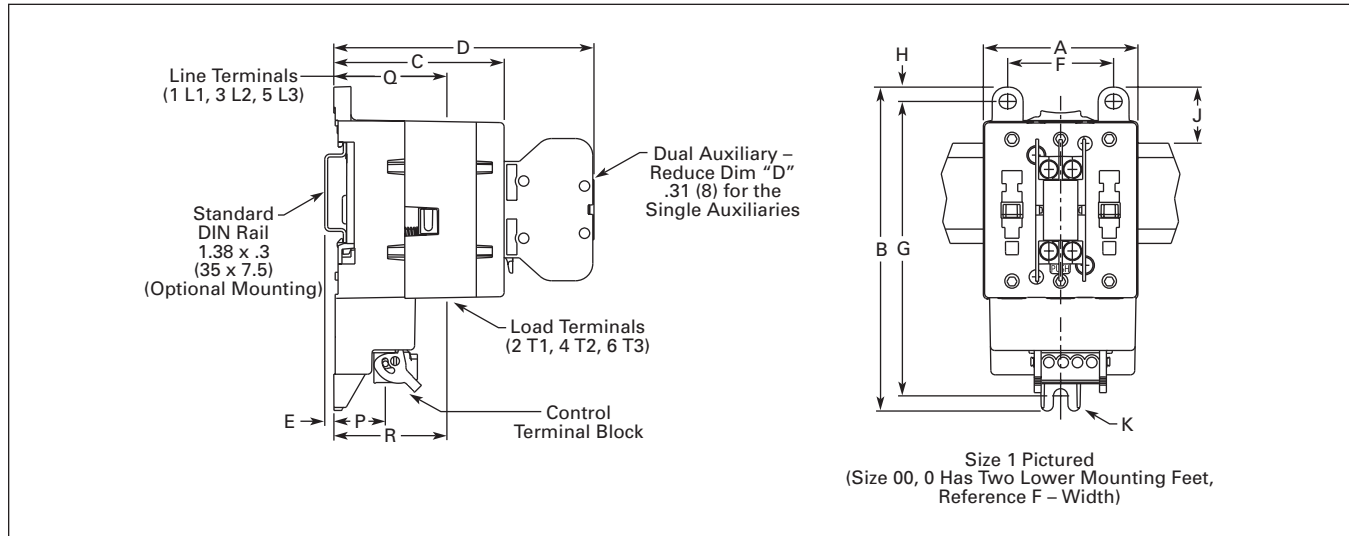

**Figure 9. Approximate Dimensions — Inches (mm)**

Dimensions

Non-reversing Contactors (Sizes 2 – 4)

Table 24. Approximate Dimensions in Inches (mm)

NEMA Size	Overall					Mounting Holes				Req. Mtg. Screws	Terminals		
	Width	Height	Depth	Depth w/ Auxiliary	Depth added w/ DIN Rail	Width	Height	Mtg. Hole to Top	DIN Rail to Top		Control	Line	Load
	A	B	C	D	E	F	G	H	J		P	Q	R
2	3.0 (76)	5.9 (150)	3.1 (79)	4.2 (107)	.2 (4)	.94 (24)	2.87 (73)	.5 (13)	.9 (23)	(4) #6 x 2 M3.5 x 50	2.4 (60)	1.5 (37)	.6 (14)
3, 4	4.1 (105)	8.0 (203)	3.5 (90)	4.7 (119)	—	1.33 (33.8)	4.13 (105)	.6 (15)	—	(4) #8 x 1.5 M4 x 40	2.8 (72)	1.7 (42)	.3 (8)

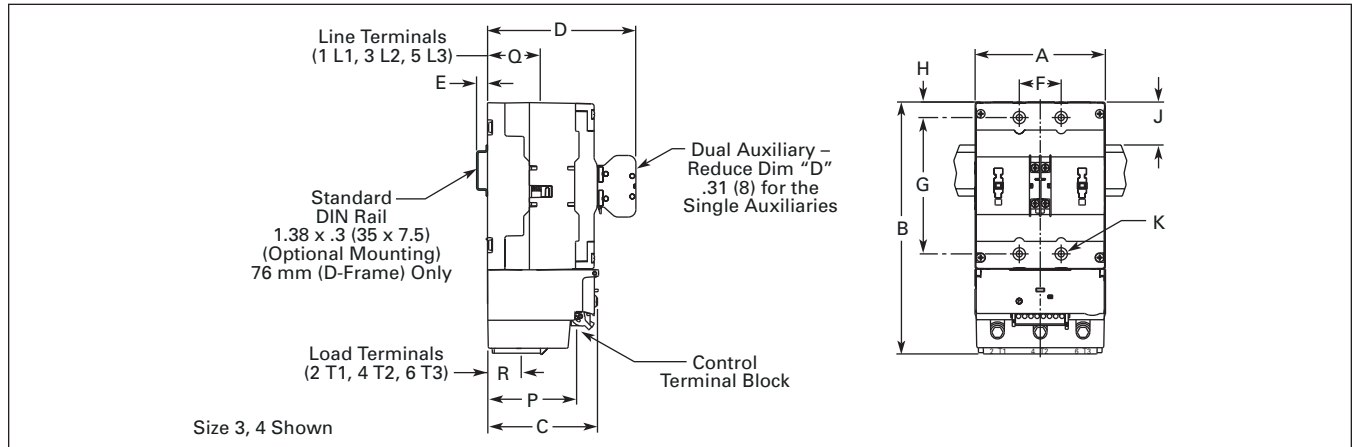

Figure 10. Approximate Dimensions — Inches (mm)

Non-reversing Contactors (Size 5)

Table 25. Approximate Dimensions in Inches (mm)

NEMA Size	Overall					Mounting Holes			Req. Mtg. Screws	Terminals		
	Width	Height	Depth	Depth w/Logic Level Auxiliary	Width w/Side Auxiliaries	Width	Height	Mounting Hole to Top		Control	Line	Load
	A	B	C	D	E	F	G	H		P	Q	R
5	5.6 (142)	14.0 (355)	7.0 (178)	8.2 (208)	6.70 (170)	1.75 (44.5)	13.0 (330)	.58 (14.7)	(4) 5/16 M8	.8 (20)	4.4 (112)	4.4 (112)

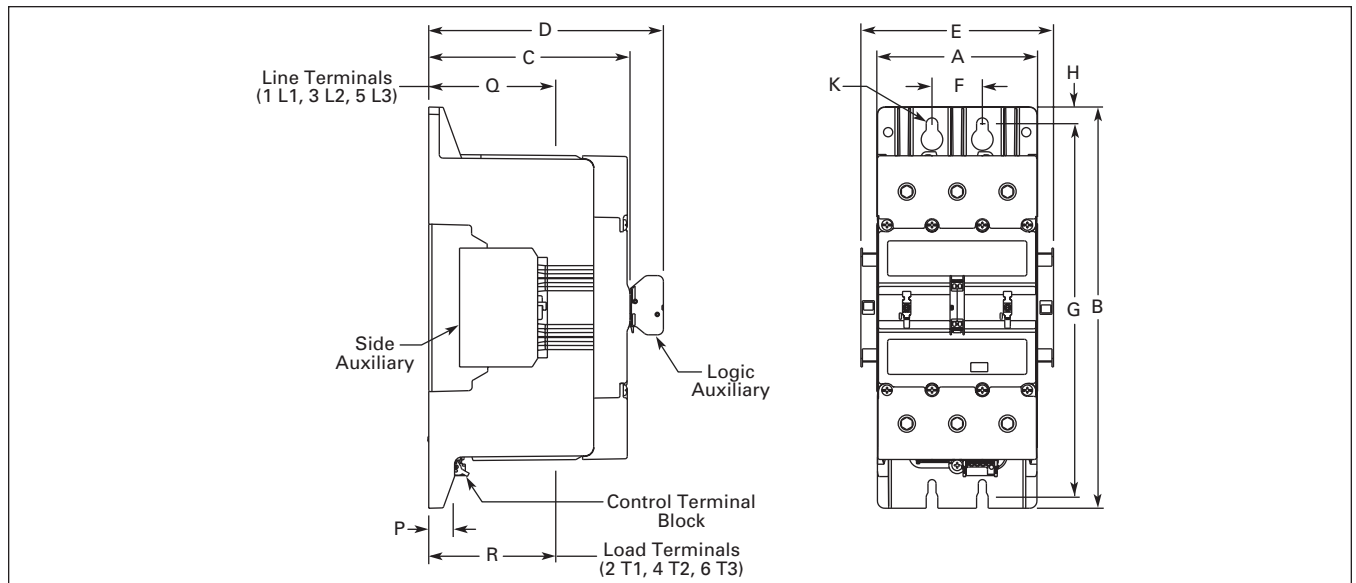

Figure 11. Approximate Dimensions in Inches (mm)

**Dimensions**

**Reversing Contactors (Sizes 00 – 4)**

**Table 26. Approximate Dimensions in Inches (mm)**

NEMA Size	Overall				Mounting Holes			Req. Mtg. Screws	Terminals		
	Width	Height	Depth	Depth w/ Auxiliary	Width	Height	Mtg. Hole to Top		Control	Line	Load
	A	B	C	D	F	G	H		P	Q	R
00, 0	3.8 (96)	5.9 (149)	2.7 (69)	3.8 (96)	3.15 (80)	5.35 (136)	.3 (7)	(3) #10 M5	2.0 (50)	1.5 (38)	.9 (22)
1	4.5 (114)	5.9 (149)	2.6 (67)	3.8 (96)	3.15 (80)	5.35 (136)	.3 (7)	(3) #10 M5	2.0 (50)	1.5 (38)	.6 (16)
2	6.2 (158)	7.4 (188)	3.3 (84)	4.4 (112)	5.51 (140)	6.89 (175)	.2 (6)	(3) #10 M5	2.6 (67)	1.9 (48)	.9 (22)
3, 4	8.5 (216)	9.5 (242)	3.8 (97)	4.9 (125)	7.87 (200)	9.06 (230)	.2 (6)	(3) #10 M5	3.1 (80)	2.1 (54)	.7 (17)

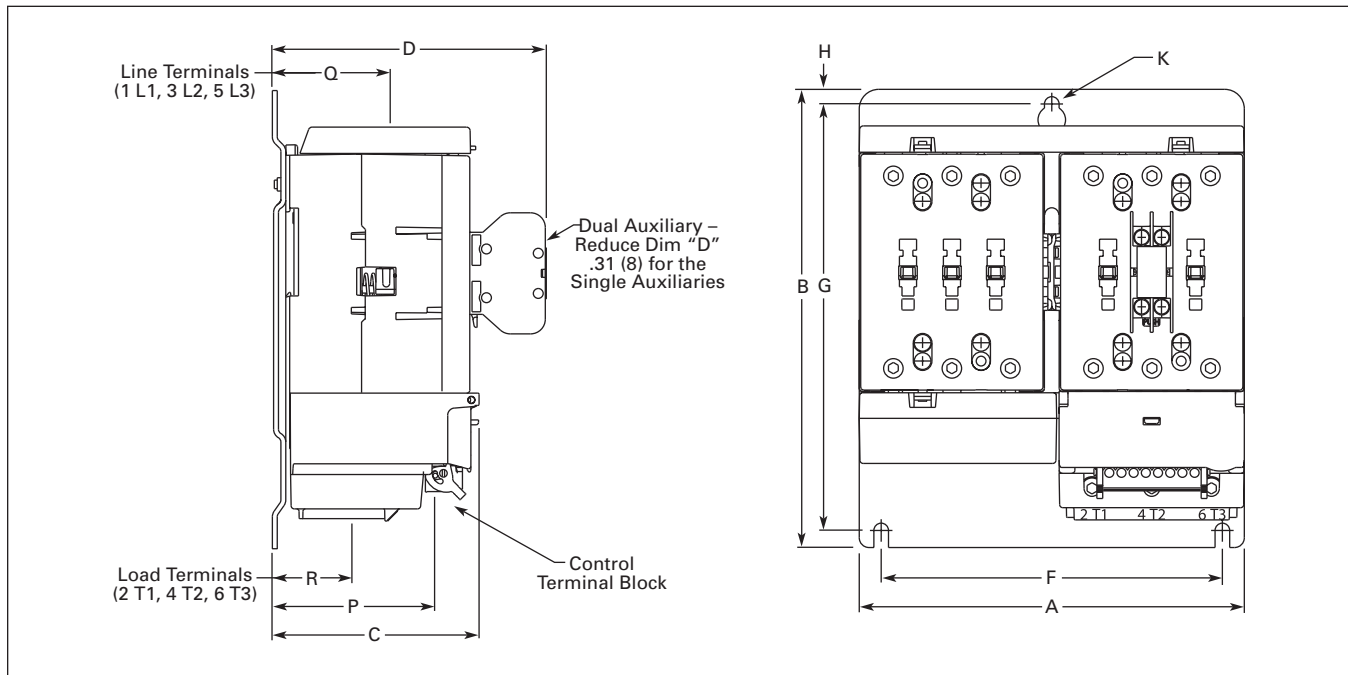

**Figure 12. Approximate Dimensions — Inches (mm)**

**Dimensions**

**Reversing Contactors (Size 5)**

**Table 27. Approximate Dimensions in Inches (mm)**

NEMA Size	Overall					Mounting Holes			Req. Mtg. Screws	Terminals		
	Width	Height	Depth	Depth w/Logic Level Auxiliary	Width w/Side Auxiliaries	Width	Height	Mounting Hole to Top		Control	Line	Load
	A	B	C	D	E	F	G	H		P	Q	R
5	11.7 (297)	17.2 (436)	7.0 (178)	8.2 (208)	12.8 (325)	7.8 (198.5)	13.0 (330)	2.19 (55.5)	(4) 5/16 M8	.8 (20)	4.4 (112)	4.4 (112)

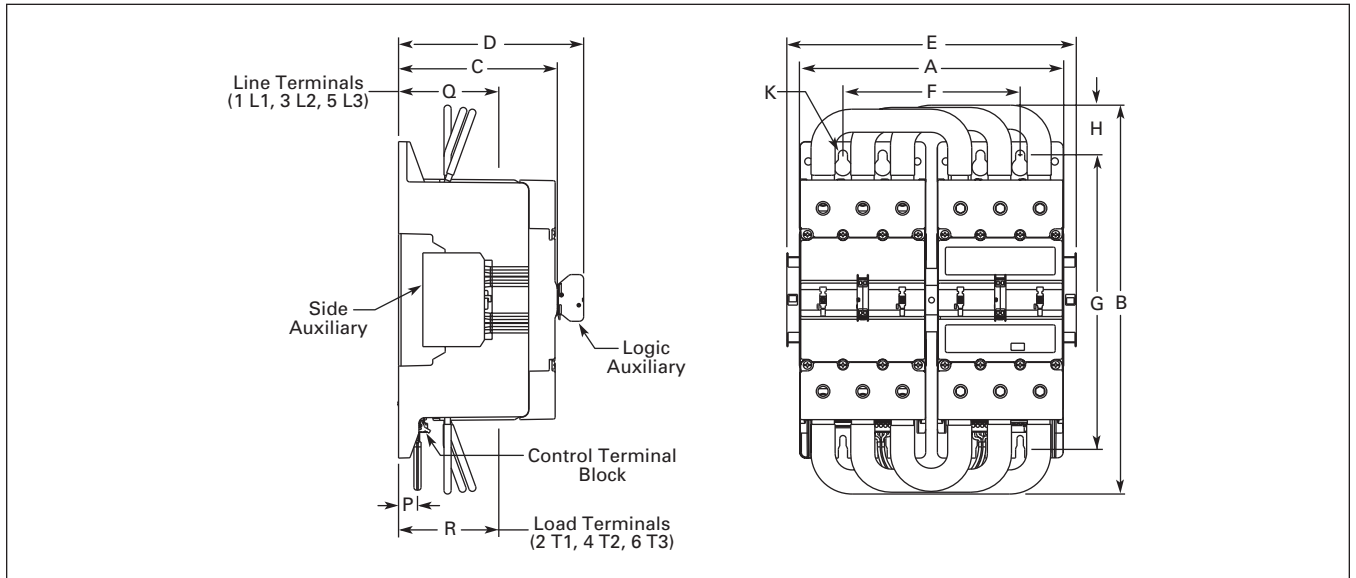

**Figure 13. Approximate Dimensions in Inches (mm)**

**Dimensions**

**Non-reversing Starters (Sizes 00 – 4)**

**Table 28. Approximate Dimensions in Inches (mm)**

NEMA Size	Overall					Mounting Holes				Req. Mtg. Screws	Reset Button			Terminals		
	Width	Height	Depth	Depth w/ Auxiliary	Depth added w/ DIN Rail	Width	Height	Mtg. Hole to Top	DIN Rail to Top		Width	Height	Depth	Control	Line	Load
	A	B	C	D	E	F	G	H	J		L	M	N	P	Q	R
00, 0	1.8 (45)	5.0 (127)	2.5 (63)	3.6 (91)	.1 (3)	1.33 (33.8)	4.62 (117.3)	.2 (5)	.9 (23)	(3) #8 M4	.6 (14)	3.6 (91)	2.5 (63)	1.7 (44)	1.2 (30)	.6 (16)
1	2.1 (54)	5.4 (138)	2.5 (63)	3.6 (91)	.1 (3)	1.46 (37)	5.04 (128)	.2 (5)	.8 (20)	(3) #8 M4	.7 (17)	3.7 (93)	2.4 (62)	1.8 (45)	1.2 (30)	.3 (8)
2	3.0 (76)	5.9 (150)	3.1 (79)	4.2 (107)	.2 (4)	.94 (24)	2.87 (73)	.5 (13)	.9 (23)	(4) #6 x 2 M3.5 x 50	.7 (17)	4.2 (106)	3.1 (78)	2.4 (60)	1.5 (37)	.6 (14)
3, 4	4.1 (105)	8.0 (203)	3.5 (90)	4.7 (119)	—	1.33 (33.8)	4.13 (105)	.6 (15)	—	(4) #8 x 1.5 M4 x 40	.7 (17)	5.7 (146)	3.5 (88)	2.8 (72)	1.7 (42)	.3 (8)

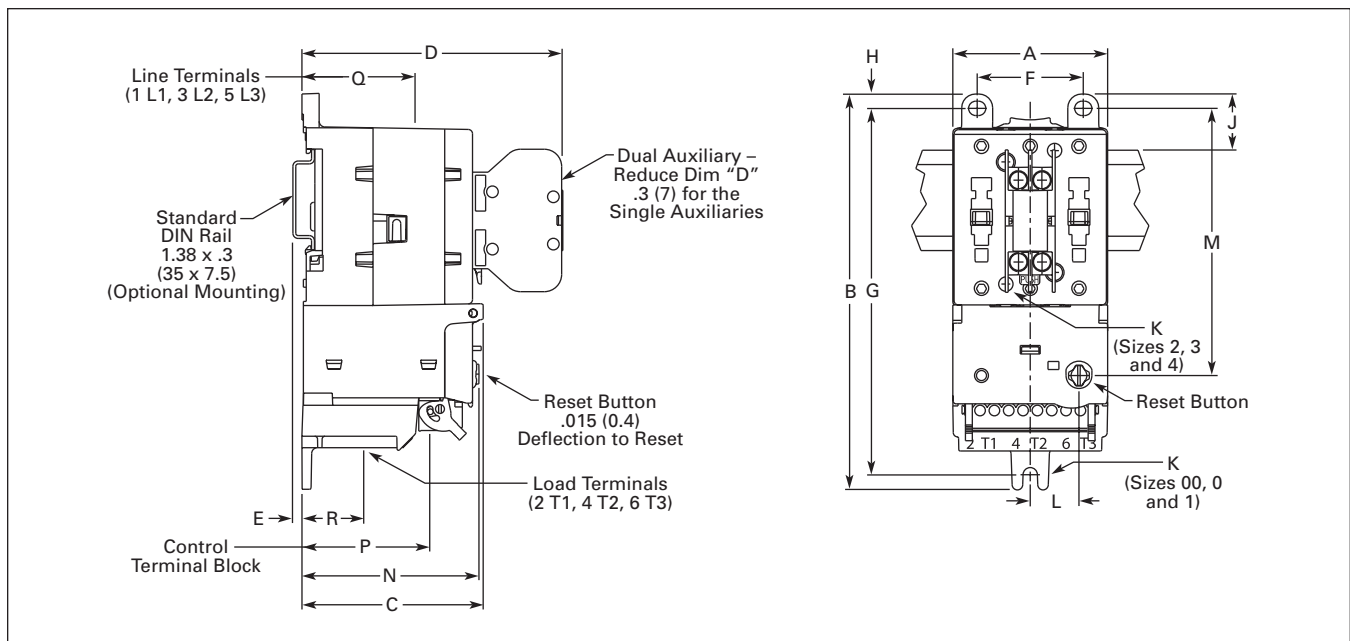

**Figure 14. Approximate Dimensions — Inches (mm)**



Dimensions

Non-reversing Starter (Size 5)

Table 29. Approximate Dimensions in Inches (mm)

NEMA Size	Overall					Mounting Holes			Req. Mtg. Screws	Reset Button			Terminals			
	Width	Length	Depth	Depth w/Logic Level Auxiliary	Width w/Side Auxiliaries	Width	Height	Mntg. Hole to Top		Width	Height	Depth	Control	Line	Load	Load
	A	B	C	D	E	F	G	I		K	L	M	N	P	Q	R
5	5.7 (145)	19.4 (492)	7.0 (178)	8.2 (208)	6.7 (170)	1.75 (44.5)	18.3 (465)	.58 (14.7)	(4) 5/16 M8	2.4 (61)	12.4 (315)	5.3 (135)	5.0 (126)	4.4 (112)	3.0 (75)	4.0 (101)

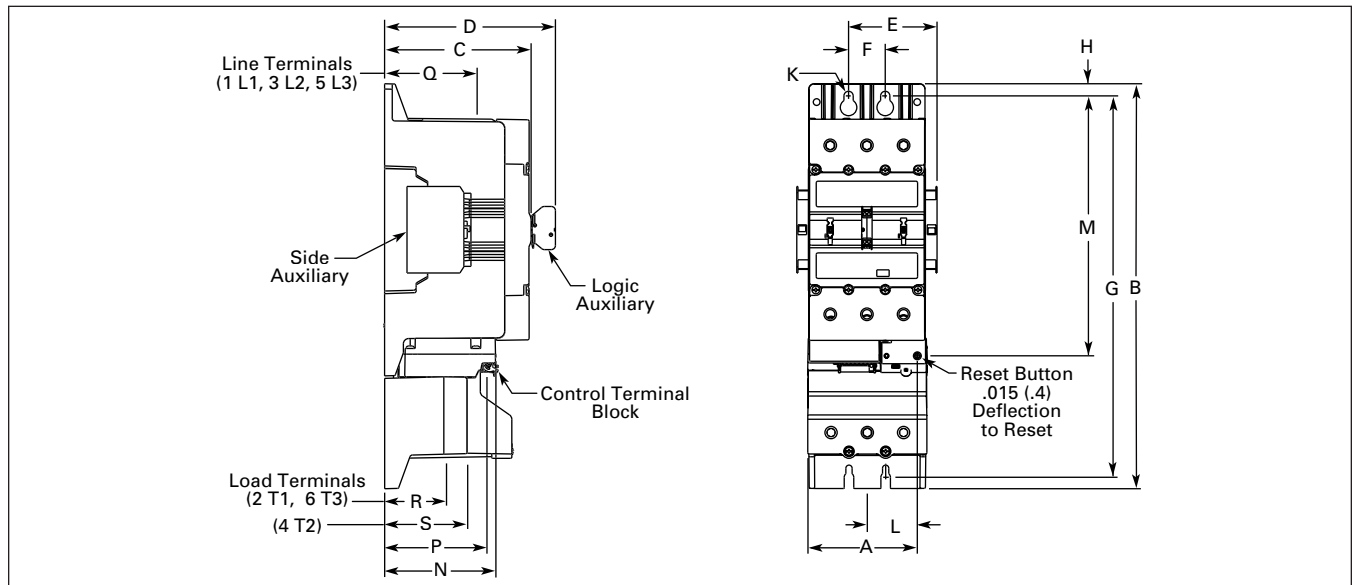

Figure 15. Approximate Dimensions in Inches (mm)

Reversing Starters (Sizes 00 – 4)

Table 30. Approximate Dimensions in Inches (mm)

NEMA Size	Overall				Mounting Holes			Req. Mtg. Screws	Reset Button			Terminals		
	Width	Length	Depth	Depth w/Auxiliary	Width	Height	Mtg. Hole to Top		Width	Height	Depth	Control	Line	Load
	A	B	C	D	F	G	H		K	L	M	N	P	Q
00, 0	3.8 (96)	5.9 (149)	2.7 (69)	3.8 (96)	3.15 (80)	5.35 (136)	.28 (7)	(3) #10 M5	1.6 (40)	3.8 (97)	2.7 (68)	2.0 (50)	1.5 (38)	.9 (22)
1	4.5 (114)	5.9 (149)	2.6 (67)	3.8 (96)	3.15 (80)	5.35 (136)	.28 (7)	(3) #10 M5	1.7 (43)	4.1 (104)	2.6 (65)	2.0 (50)	1.5 (38)	.6 (16)
2	6.2 (158)	7.4 (188)	3.3 (84)	4.4 (112)	5.51 (140)	6.89 (175)	.24 (6)	(3) #10 M5	2.3 (58)	5.5 (139)	3.3 (83)	2.6 (67)	1.9 (48)	.9 (22)
3, 4	8.5 (216)	9.5 (242)	3.8 (97)	4.9 (125)	7.87 (200)	9.06 (230)	.24 (6)	(3) #10 M5	2.9 (73)	7.2 (182)	3.7 (94)	3.1 (80)	2.1 (54)	.7 (17)

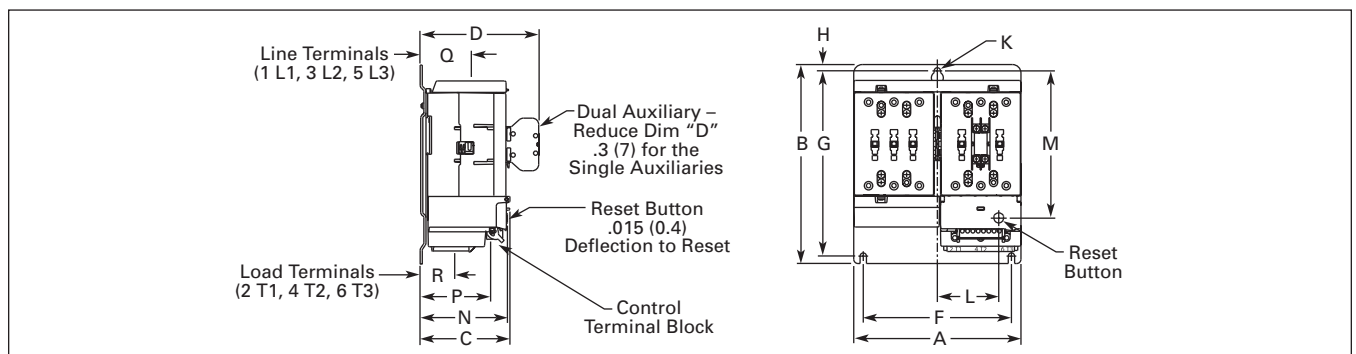

Figure 16. Approximate Dimensions — Inches (mm)

**Dimensions**

**Reversing Starter (Size 5)**

**Table 31. Approximate Dimensions in Inches (mm)**

NEMA Size	Overall					Mounting Holes				Req. Mtg. Screws	Reset Button			Terminals			
	Width	Length	Depth	Depth w/Logic Level Auxiliary	Width w/Side Auxiliaries	Width	H1	Mntg. Hole to Top	H2		Width	Height	Depth	Control	Line	Load	Load
	A	B	C	D	E	F	G	H	I		L	M	N	P	Q	R	S
5	11.8 (300)	21.0 (533)	7.0 (178)	8.2 (208)	12.8 (325)	7.82 (199)	18.3 (465)	2.19 (55.5)	13 (330)	(5) 5/16 M8	5.4 (138)	12.4 (315)	5.3 (135)	5.0 (126)	4.4 (112)	3.0 (75)	4.0 (101)

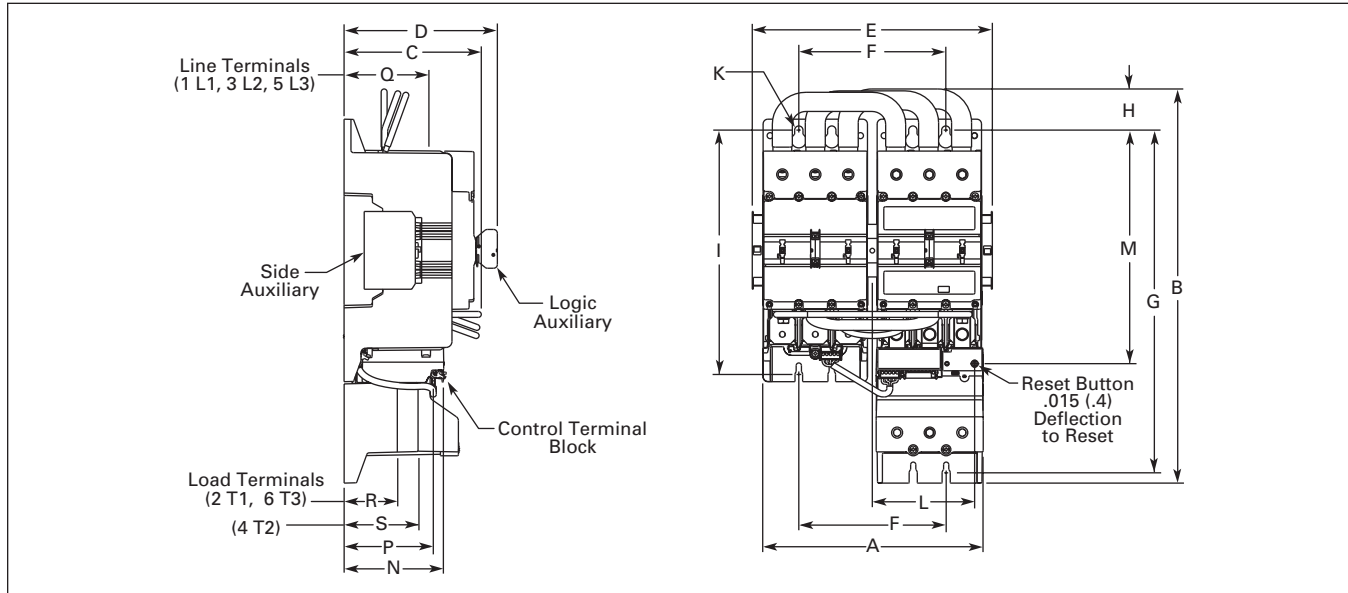

**Figure 17. Approximate Dimensions in Inches (mm)**

Eaton Corporation  
Cutler-Hammer business unit  
1000 Cherrington Parkway  
Moon Township, PA 15108-4312  
USA  
tel: 1-800-525-2000  
www.cutler-hammer.eaton.com

© 2003 Eaton Corporation  
All Rights Reserved  
Printed in USA  
Publication No. CA03310002E/CPG  
September 2003